

THERMODYNAMIC STEAM TRAPS DT 32

DESCRIPTION

Thermodynamic DT32 disc steam traps are compact and lightweight-easy to install traps, excellent for high pressure systems, including steam tracing applications.

A heating chamber in the cover ensures a consistent operation and makes it particularly suitable for those applications where the weather conditions such as rain and wind may affect the normal operation.

These traps have only one moving part and offer a wide operating range, without adjustment.

Connections are female screwed or flanged.

MAIN FEATURES

Intermittent discharge.

Unaffected by water-hammer and vibrations

Steam jacketed capsule (disc and cover set).

Replaceable capsule

Built-in easy-to-clean strainer.

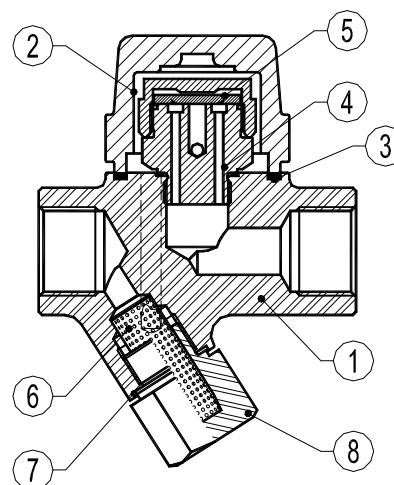

- OPTIONS:** Blow-off valve
USE: Saturated and superheated steam.
AVAILABLE MODELS: DT 32
SIZES: DN ½" to DN 1" – DN15 to DN25
CONNECTIONS: Female screwed ISO7/1 Rp (BS21)
 Flanged EN 1092-1 PN40
INSTALLATION: Horizontal installation recommended.
 Can be installed in any position.
APPLICATION LIMITS: Min-working pressure – 0,25 bar
 Max. working back pressure – 80%

- PMA** – Max. allowable pressure 40 bar
TMA – Max. allowable temperature 400 °C
PMO – Max. operating pressure 32 bar
TMO – Max. operating temperature 350 °C
 How to order: i.e. DT32 DN ½" BSP

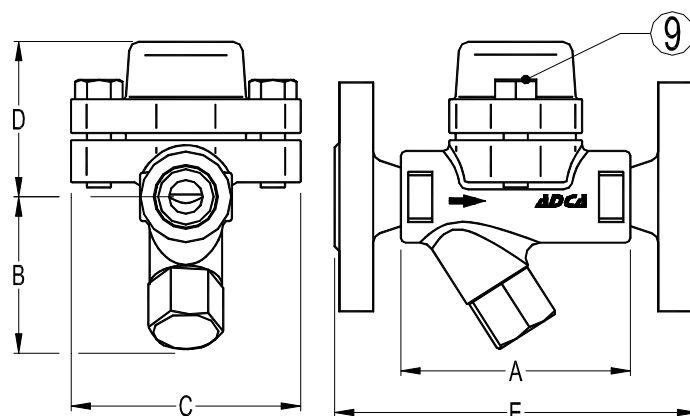

DIMENSIONS (mm)-Screwed					EN Flanges		
SIZE DN	A	B	C	D	WGT. Kgs	E	WGT. Kgs
15	95	65	95	65	1,6	150	3,2
20	95	65	95	65	1,6	150	3,3
25	95	65	95	65	1,8	160	4,7

MATERIALS		
POS.Nr.	DESIGNATION	MATERIAL
1	Body	P250GH / 1.0460
2	Cover	P250GH / 1.0460
3	*Gasket	Graphite
4	*Seat	Hardened St.Steel
5	*Valve disc	Hardened St.Steel
6	*Strainer screen	AISI 304 / 1.4301
7	*Gasket	Stainless st. / Graphite
8	Plug	A105 / 1.0432
9	Bolts	A2-70

*Available spare parts.

FLOW RATE CAPACITY IN Kgs/h														
MODEL	SIZE	DIFFERENTIAL PRESSURE (bar)												
		0,5	1	2	3	6	8	10	12	15	18	21	24	32
DT 32	15 - 25	130	180	200	240	355	410	500	550	600	640	710	750	800